

RANGE
4WD
4 WHEEL DRIVE



 **SC917**
TRANSAXLE

SADEV[®]
RACING TRANSMISSION

SADEV
RACING TRANSMISSION

RANGE
4WD
4 WHEEL DRIVE

SC917
TRANSAXLE



Specially designed for extreme applications, the **SC917** is the benchmark for longitudinal rallycross gearboxes. Benefiting from all SADEV's experience, it combines optimised architecture with a small footprint and a low weight. Incorporating innovations such as a low-friction differential and a reverse lockout solenoid, the **SC917** will prove a formidable solution for your future projects.

APPLICATIONS

- › Circuit
- › Hill Climb
- › Rallycross
- › Rally



TECHNICAL SPECS

6 speed sequential gearbox + 1 reverse gear

Manual sequential gear selection

Wide range of final drives available

Wide range of ratios available

Straight cut gears

Dog ring gear engagement

Interchangeable gear ratios

High strength carburizing steel

Gear teeth grinded with optimized profile

Specific input shaft

Shot penning on internal parts

Central limited slip differential (optional low friction)

Ramp and plate system - 3 discs type

Wide range of ramp plates available

Differential locking system

Reverse lockout cable (solenoid system optional)

Contactless gear position sensor

Contactless flat shift sensor

Directed and pressurised lubrication on the gears

Magnetic drain plugs

Painted AS7G aluminum casings

Angle possible -15° to 195°

Weight (input shaft included) : 47 Kg - 103 lbs

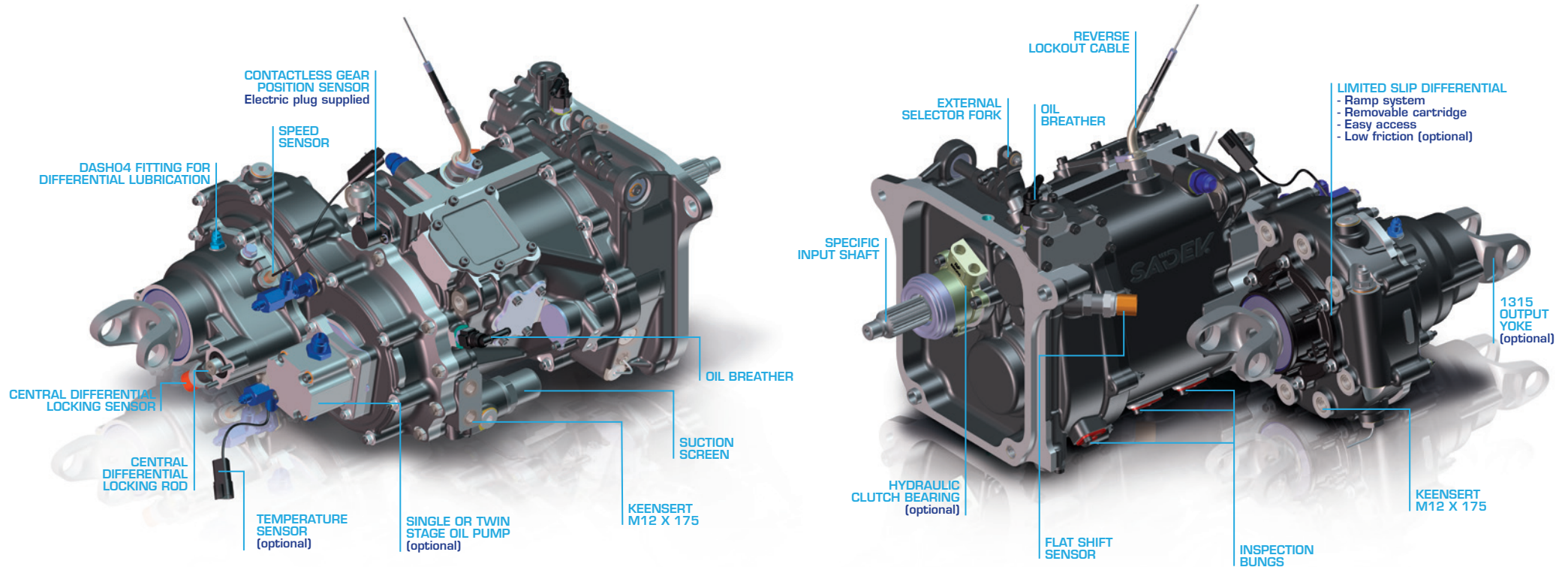

ACCESSORIES

- › Gearlever
- › Gear Display
- › Bell housing
- › Propshaft

LIMITED SLIP DIFFERENTIAL

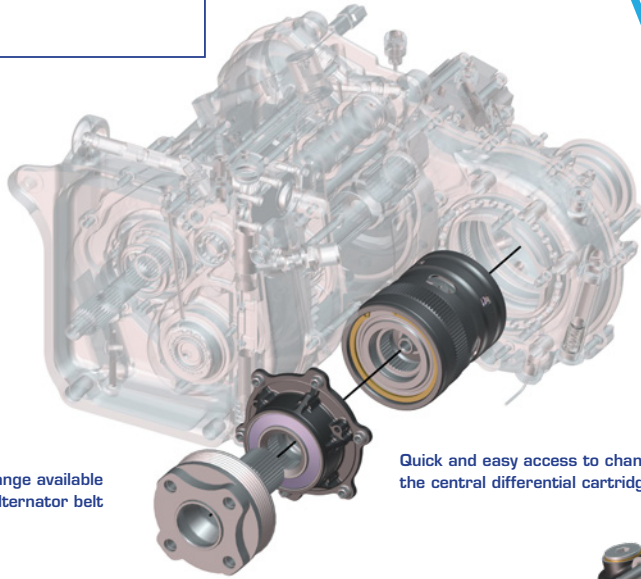

Output pulley flange available to drive an alternator belt

Quick and easy access to change the central differential cartridge

REPLACEABLE DROP GEAR

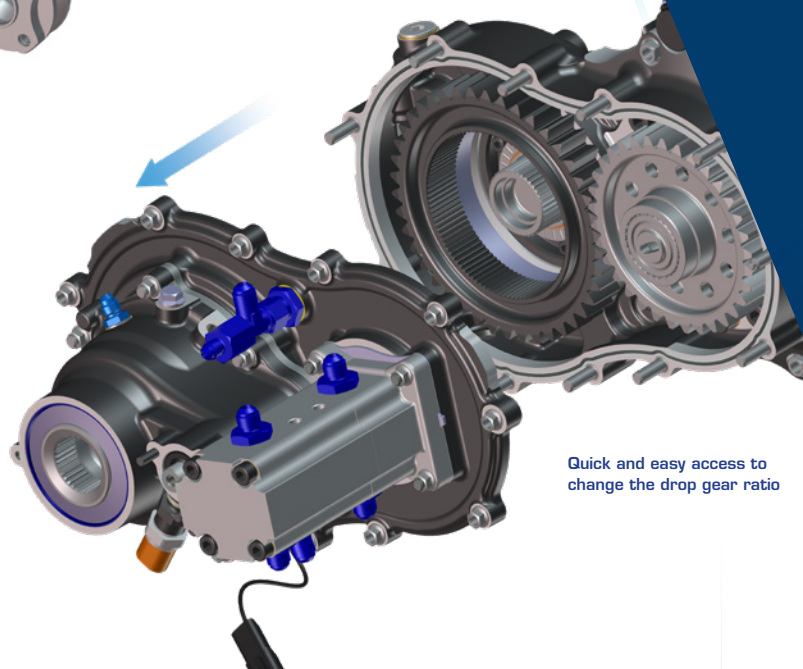

Quick and easy access to change the drop gear ratio

TRANSFER CASE ANGLES

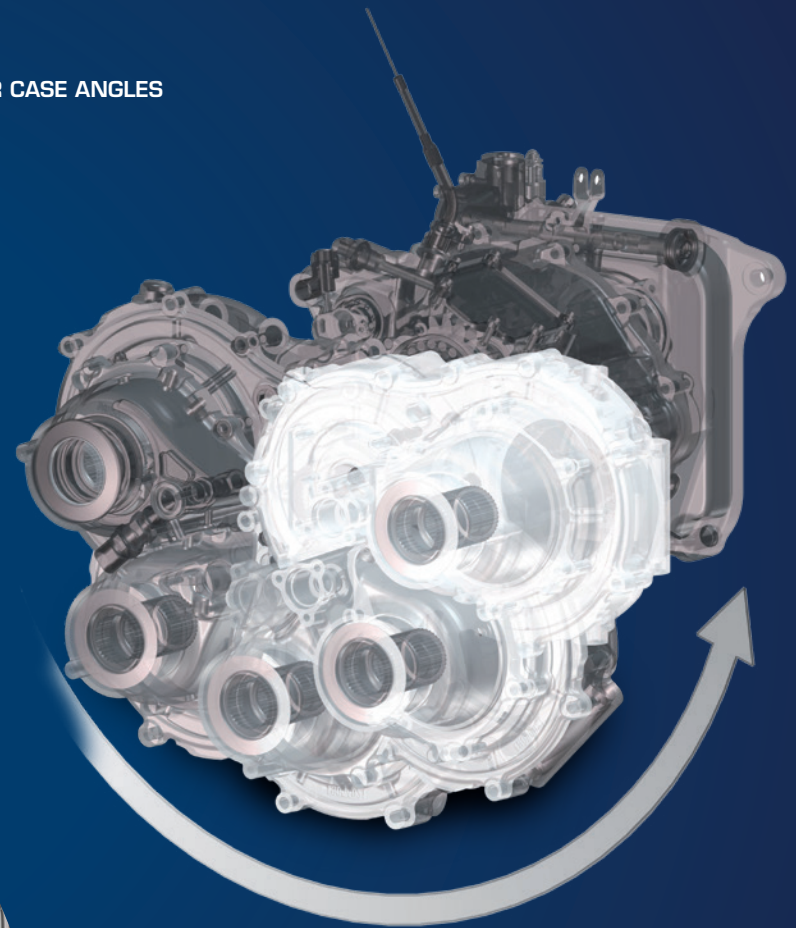

The transfer case can rotate from -15° to 195°



SC917 TRANSAXLE

- › **Ratio selection:** Optimised clutch and control shaft definition for smoother gear shifting.
- › **Gears:** The **SC917** benefits from optimised and strengthened gear tooth profiles for maximum efficiency.
- › **Limited slip self-locking ramp differential:** Optimised teeth version available as an option.
- › **Differential locking:** Option to lock the central differential mechanically.
- › **Architecture:** The offset geartrains mean the engine and gearbox can be positioned as low as possible.
- › **Robustness:** Our finite element calculation tool enables us to design extremely strong, compact, lightweight casings.
- › **Weight:** The **SC917** is currently the lightest longitudinal gearbox on the market for rallycross applications.

MAXIMUM ENGINE TORQUE

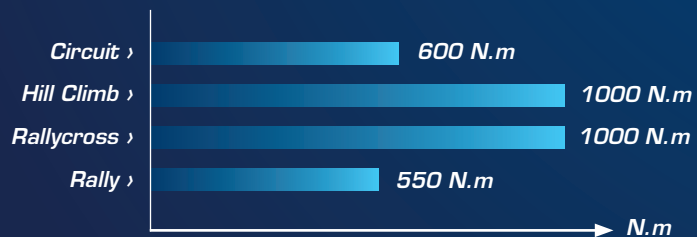



ONE PASSION: VICTORY

SADEV has an exceptional record in supplying unique engineering to the most prestigious drivers and manufacturers. SADEV's products stand out for their technology, their excellence and their ambition. As precise as they are reliable, these high-tech masterpieces are the key to your victory. SADEV has just one goal: to make sure you win.

FOLLOW US



WWW.SADEV-TM.COM

6, rue Grand'Montains - 85110 SAINT-PROUANT - FRANCE

Tel: +33 (0)2 51 66 42 68

sadev@sadev-tm.com



A TEAM AT YOUR SIDE

FRANCE	SADEV FRANCE - sadev@sadev-tm.com
USA	SADEV TRANSMISSIONS, INC. - info.usa@sadev-tm.com
UK	SWR MOTORSPORT LTD - serviceswrmotorsport@gmail.com
ITALY	GIEFFE RACING - info@giefferacing.com
SPAIN	DE LA PUENTE MOTORSPORT - dlpmotorsport@movistar.es
NETHERLANDS	RACING DEVELOPMENT - info@racingdevelopment.nl
NETHERLANDS	PETERS AUTOSPORT - bart@petersautosport.nl
BELGIUM	R TEC - info@rtec.ws
CZECH REPUBLIC	SADAC - info@sadac.cz
GERMANY	MTO ENGINEERING - info@mtoengineering.com
SWEDEN	HANSEN MOTORSPORT - kenneth@hansen-motorsport.se
DENMARK	GUNNAR AASKOV MOTORSPORT - mail@aaaskov-motorsport.dk
FINLAND	SET PROMOTION - kalle.pinomaki@setpromotion.com
SWITZERLAND	CHRISTIAN FERRARI - ferrach@bluewin.ch
SOUTH AFRICA	CENTURY RACING - julien@centuryracing.co.za
ARGENTINA	JPO RACING - racingjpo@gmail.com
BRAZIL	CD MOTORSPORT ENGINEERING - sadev.brasil@gmail.com

