

RANGE
2WD
2 WHEEL DRIVE



 **SL75LW**
TRANSAXLE

SADEV
RACING TRANSMISSION

SADEV
RACING TRANSMISSION

RANGE
2WD
2 WHEEL DRIVE

SL75LW TRANSAXLE



Drawing on decades of experience in the single-seater world, SADEV has perfected the **SL75LW**, an ingenious blend of creativity and technology.

Its many possible technical configurations make this an "à la carte" product that can adapt to your application. It is available in a simplified version, with five speeds and free differential, and a high-performance version with self-locking limited slip differential, six speeds and integrated paddle shift.

APPLICATIONS

- › *Circuit*
- › *Hill Climb*
- › *Single-seater*



TECHNICAL SPECS

5 or 6 speed sequential gearbox + 1 reverse gear

Manual sequential gear selection (semi-auto optional)

External selector rocker (optional)

Bevel gear ratio : 10x31 or 8x31

The bevel gear is cut and grinded in house on our CNC units

Wide range of ratios available

Straight cut gears

Dog ring gear engagement

Interchangeable gear ratios

High strength carburizing steel

Gear teeth grinded with optimized profile

Shot penning on internal parts

Specific input shaft

Free differential (limited slip differential optional)

Ramp and plate system - 3 discs type

Preload made by belleville spring washer

Wide range of ramp plates available

Reverse lockout cable

Contactless gear position sensor

Splash lubrication system

Magnetic drain plugs

Painted AS7G aluminum casings

Weight (input shaft included) : 37 Kg - 81 lbs

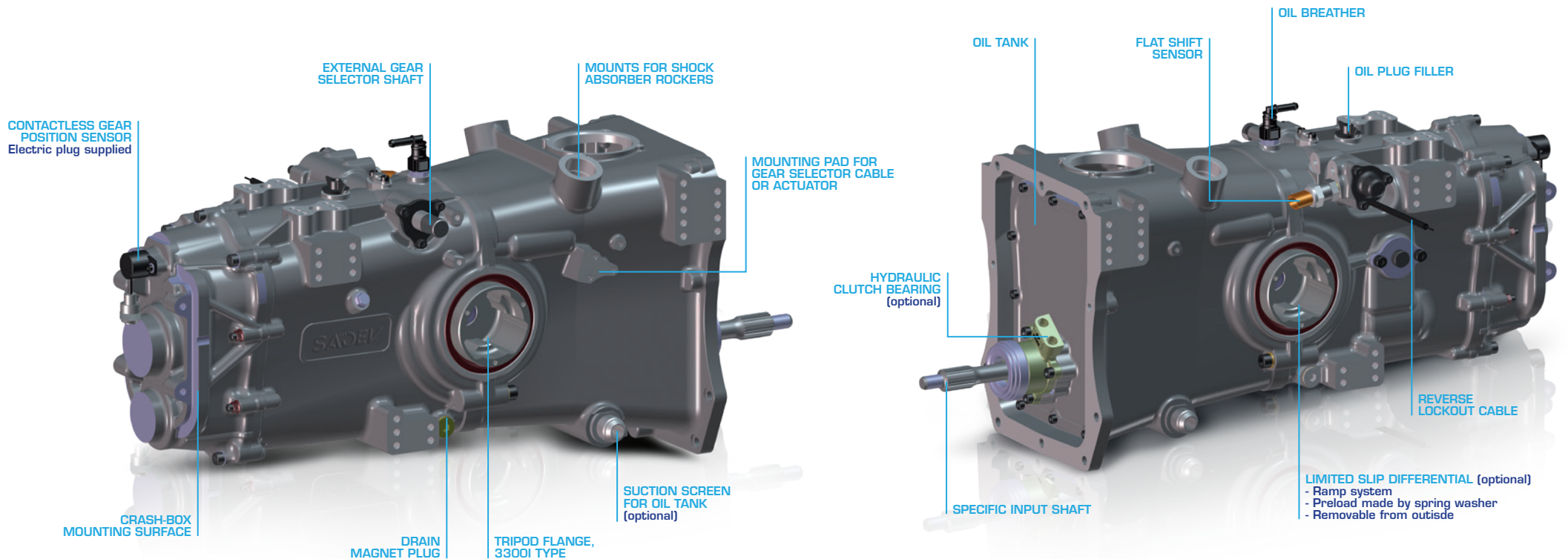

ACCESSORIES

- › Gear display
- › Push-pull cable
- › Mounting plate
- › Hydraulic paddle-shift
- › Drive shafts

LIMITED SLIP DIFFERENTIAL

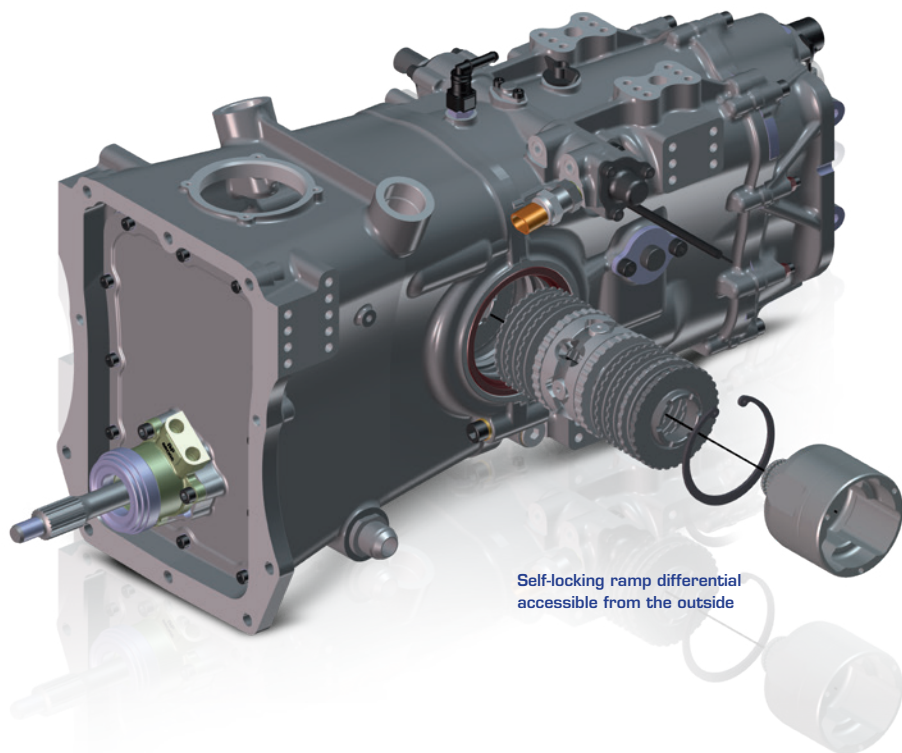

Self-locking ramp differential
accessible from the outside

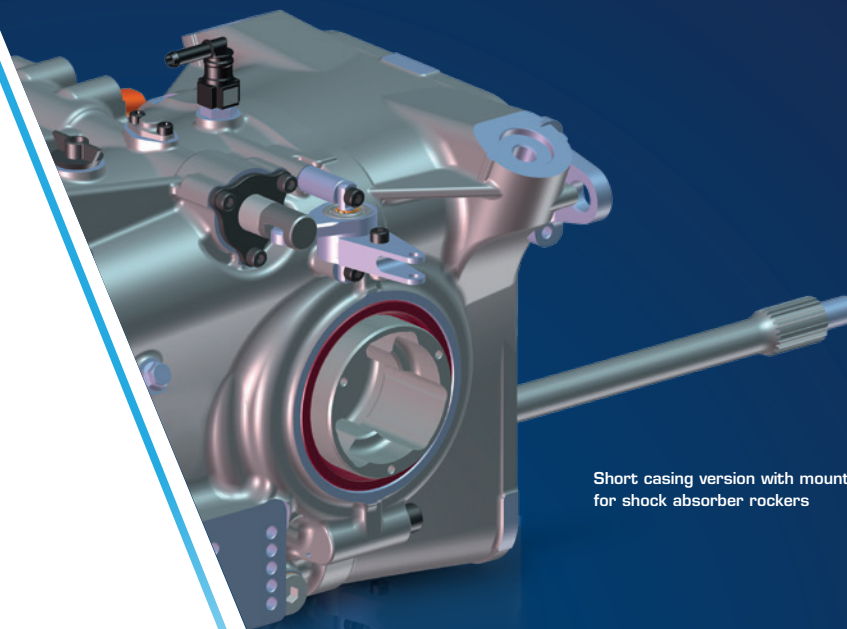

SL75LW SHORT VERSION 1

Short casing version with mounting points
for shock absorber rockers

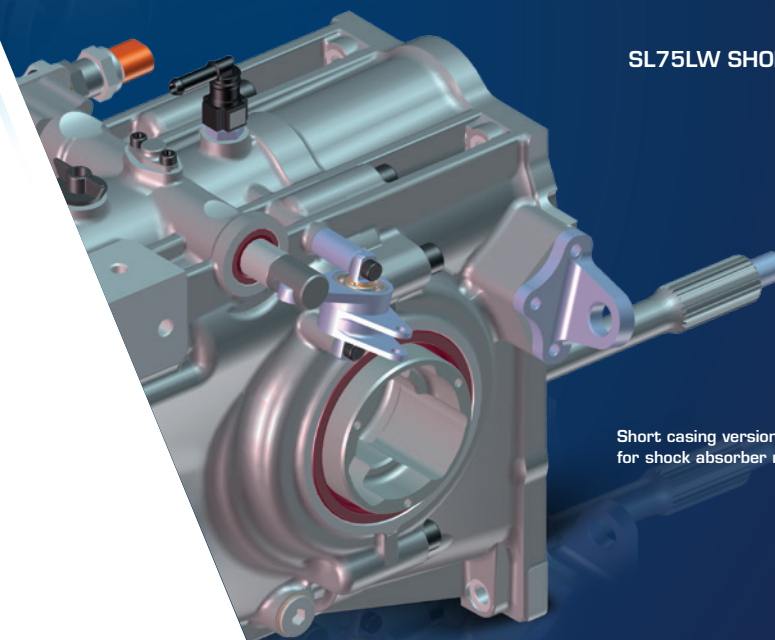

SL75LW SHORT VERSION 2

Short casing version without mounting points
for shock absorber rockers



SL75LW TRANSAXLE

- › **Robustness:** The new design for the casing, created using finite element calculation software, has increased its rigidity and reduced its mass.
- › **Oil capacity:** The optimised casing design reduces the quantity of oil needed.
- › **Gears:** The internal components have demonstrated great reliability in all past projects.
- › **Indicator:** The potentiometer included is contactless.
- › **Rear casing:** The structure of the rear casing is designed so that the crash box module and single-seater wing can be fixed to it.
- › **Differential:** A free differential version is available for categories with cost limits. This differential can be replaced with a limited slip version.
- › **Selection:** An internal actuator can be fitted to the **SL75LW** to receive the SADEV hydraulic paddle-shift system.

MAXIMUM ENGINE TORQUE

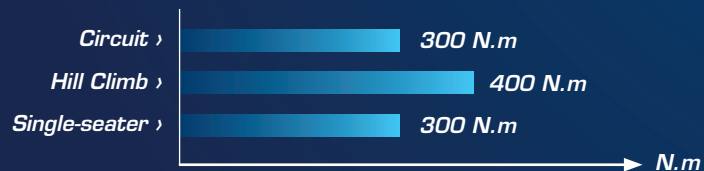



**ONE PASSION:
VICTORY**

SADEV has an exceptional record in supplying unique engineering to the most prestigious drivers and manufacturers. SADEV's products stand out for their technology, their excellence and their ambition. As precise as they are reliable, these high-tech masterpieces are the key to your victory. SADEV has just one goal: to make sure you win.

FOLLOW US



WWW.SADEV-TM.COM

6, rue Grand'Montains - 85110 SAINT-PROUANT - FRANCE

Tel: +33 (0)2 51 66 42 68

sadev@sadev-tm.com



A TEAM AT YOUR SIDE

- FRANCE** SADEV FRANCE - sadev@sadev-tm.com
- USA** SADEV TRANSMISSIONS, INC. - info.usa@sadev-tm.com
- UK** SWR MOTORSPORT LTD - servicesswrmotorsport@gmail.com
- ITALY** GIEFFE RACING - info@giefferacing.com
- SPAIN** DE LA PUENTE MOTORSPORT - dlpmotorsport@movistar.es
- NETHERLANDS** RACING DEVELOPMENT - info@racingdevelopment.nl
- NETHERLANDS** PETERS AUTOSPORT - bart@petersautosport.nl
- BELGIUM** R TEC - info@rtec.ws
- CZECH REPUBLIC** SADAC - info@sadac.cz
- GERMANY** MTO ENGINEERING - info@mtoengineering.com
- SWEDEN** HANSEN MOTORSPORT - kenneth@hansen-motorsport.se
- DENMARK** GUNNAR AASKOV MOTORSPORT - mail@aaaskov-motorsport.dk
- FINLAND** SET PROMOTION - kalle.pinomaki@setpromotion.com
- SWITZERLAND** CHRISTIAN FERRARI - ferrach@bluewin.ch
- SOUTH AFRICA** CENTURY RACING - julien@centuryracing.co.za
- ARGENTINA** JPO RACING - racingjpo@gmail.com
- BRAZIL** CD MOTORSPORT ENGINEERING - sadev.brasil@gmail.com

