

RANGE
2WD
2 WHEEL DRIVE

 **SL90-23**
TRANSAXLE

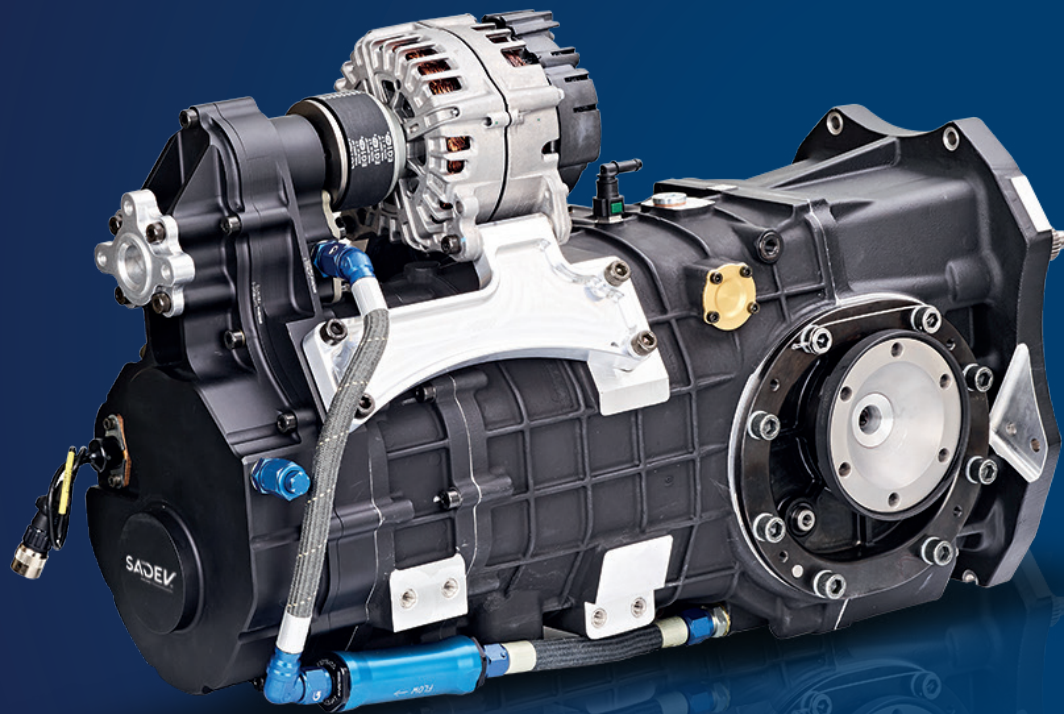

SADEV[®]
RACING TRANSMISSION

SADEV
RACING TRANSMISSION

RANGE
2WD
2 WHEEL DRIVE

 **SL90-23**
TRANSAXLE

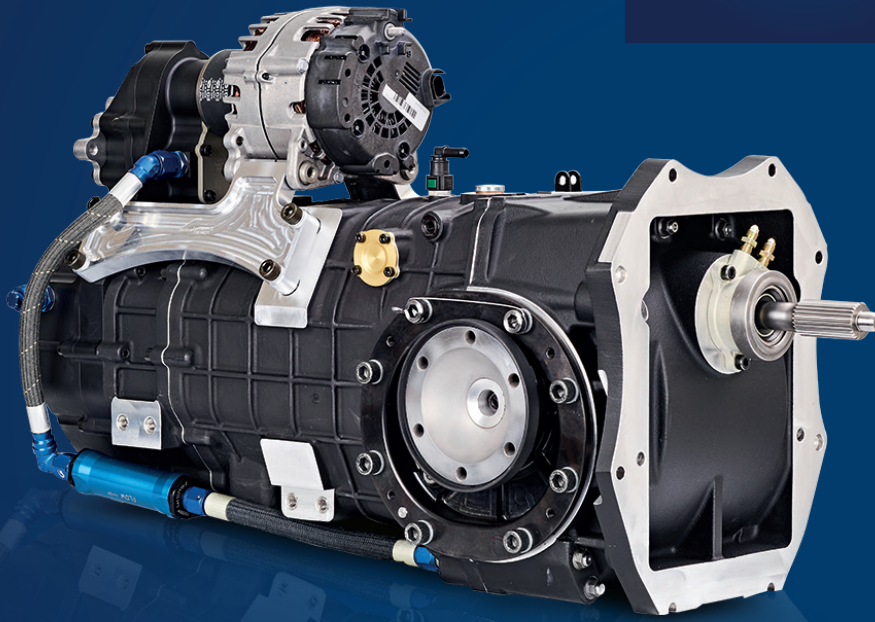

Designed primarily for two-wheel-drive rally-raid, the **SL90-23** is designed for driving across dunes, steppes and the the trickiest terrain. Thanks to its ingenious design, it absorbs heavy loads from V8-type engines and sudden increases in torque administered by the most difficult circuits.

APPLICATION

› Rally-raid



TECHNICAL SPECS

6 speed sequential gearbox + 1 reverse gear

Super-polished bevel gear ratio 9x34 or 8x35

The bevel gear is cut and grinded in house on our CNC units

Wide range of ratios available

Straight cut gears

Dog ring gear engagement

Interchangeable gear ratios

High strength carburizing steel

Gear teeth grinded with optimized profile

Shot penning on internal parts

Specific input shaft

Hydraulic clutch bearing

Central limited slip differential

Ramp and plate system - 3 discs type

Preload made by belleville spring washer

Wide range of ramp plates available

Reverse lockout cable or option of solenoid

Splash lubrication system

Oil pump integrated

Directed and pressurised lubrication on the gears and bevel gear

Oil suction screen

Magnetic drain plugs

Painted AS7G aluminum casings

Assembled with spacers and studs

Weight (input shaft included) : 85 kg - 187 lbs

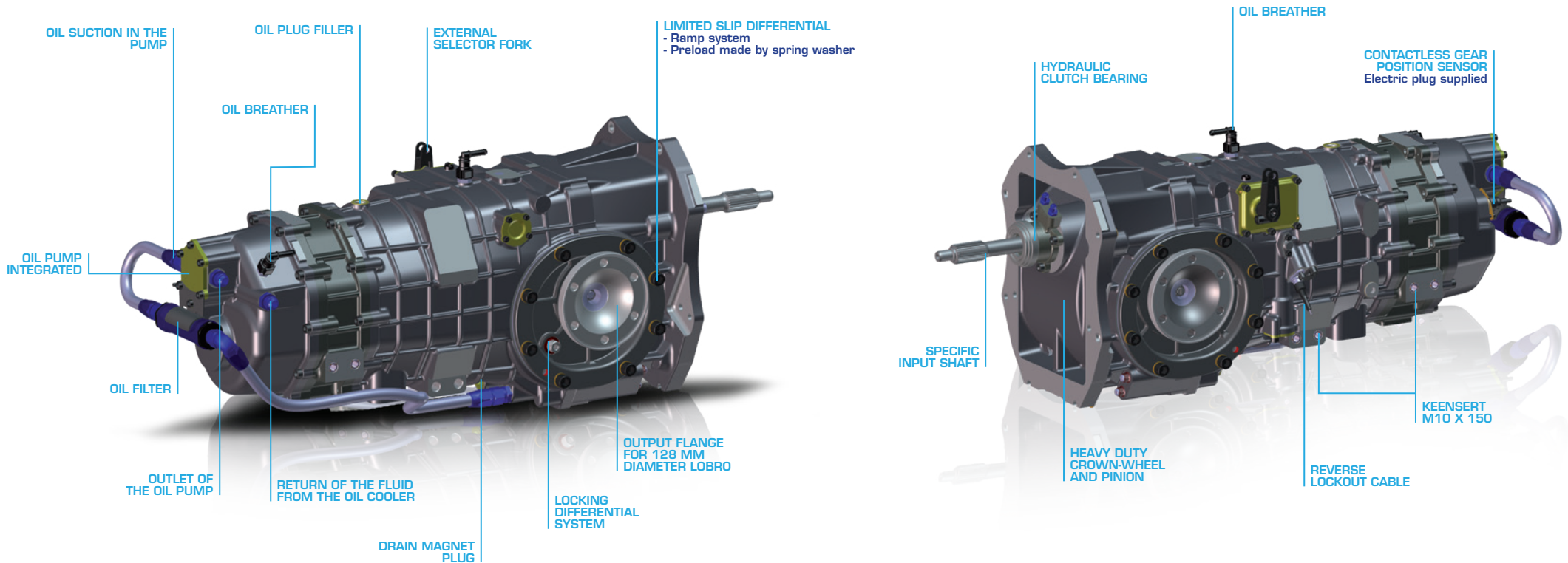

ACCESSORIES

- › Gear display
- › Mounting plate
- › Gearlever
- › Drive shafts

GEAR REDUCTION TO DRIVE AN ALTERNATOR AND STEERING PUMP (OPTIONAL)

POSSIBILITY TO DRIVE AND MOUNT AN ENGINE ALTERNATOR ON THE TRANSMISSION

- At 23° C : 221 Amperes for 6000 rpm
- At 80° C : 190 Amperes for 6000 rpm
- Rotation of the output = Engine rotation x (24/16)
- Alternator can be supplied by SADEV

POSSIBILITY TO DRIVE AND MOUNT A STEERING PUMP ON THE TRANSMISSION.

- Rotation of the output = Engine rotation x (24/22)

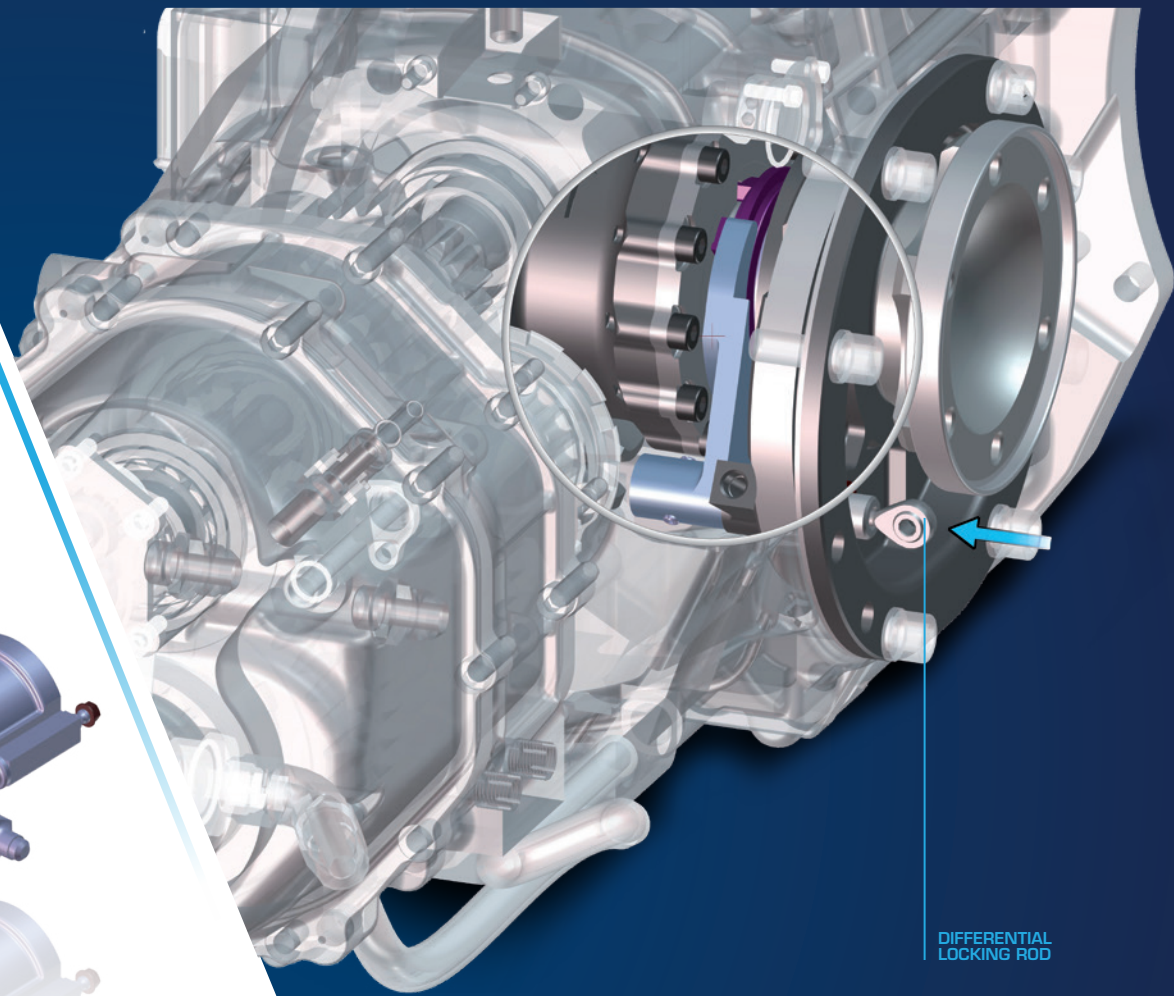
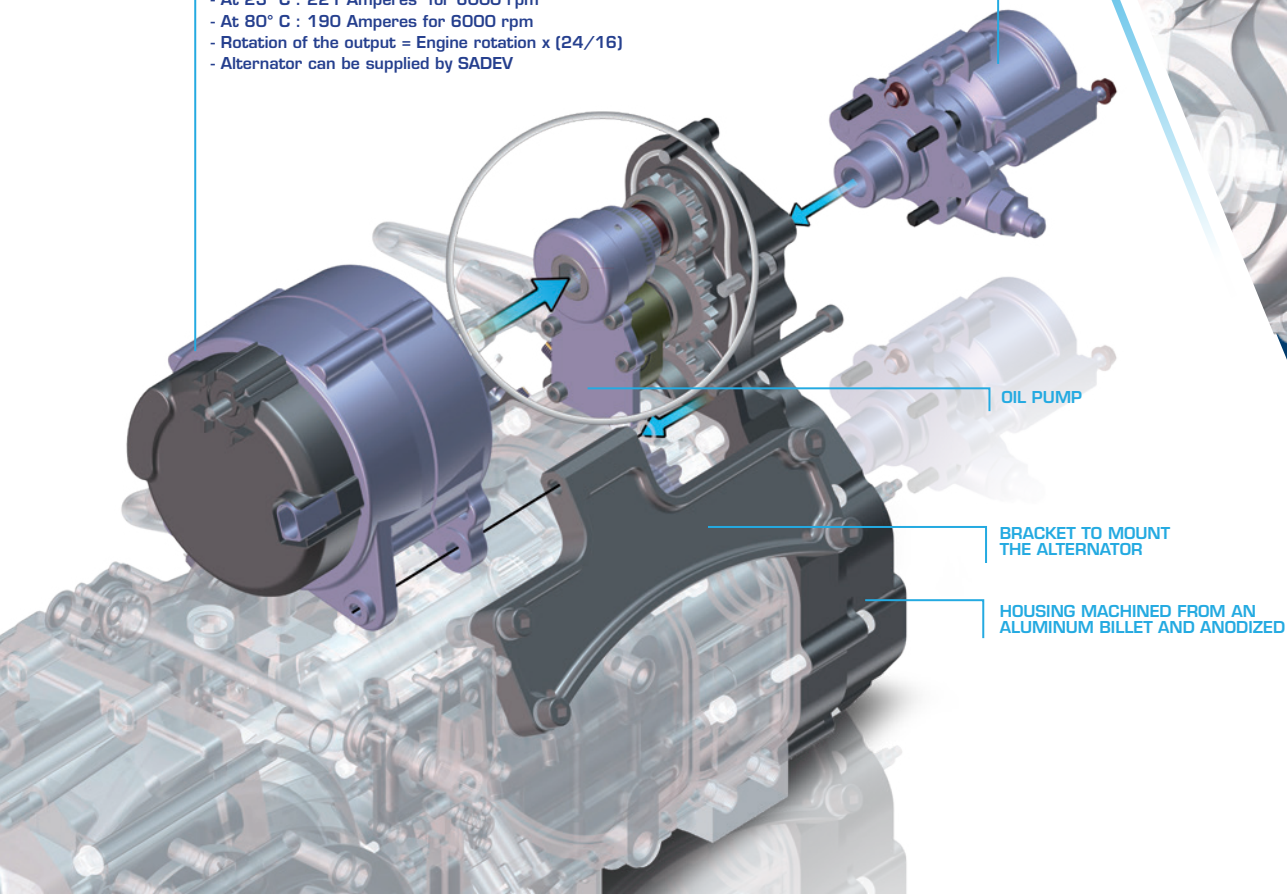

DIFFERENTIAL LOCKING SYSTEM

The locking of the limited slip differential helps you to cross the toughest roads



SL90-23 TRANSAXLE

- › **Reliability:** With several Dakar rallies and major off-road races under its belt, the **SL90-23** offers proof of its reliability, an important criterion for off-road racing.
- › **Robustness:** Our finite element calculation tool enables us to design extremely strong, compact, lightweight casings.
- › **Gears:** The **SL90-23** benefits from optimised and strengthened gear tooth profiles for maximum efficiency.
- › **Ratio selection:** Optimised clutch and control shaft definition for smoother gear shifting.
- › **Differential locking:** Possibility of locking the front differential mechanically for the best traction on sandy terrain.
- › **Cooling:** An oil pump built into the **SL90-23** and driven mechanically enables an external oil cooler to be connected. The internal circuit and directed lubrication maintain the best operating temperature for optimum reliability.

MAXIMUM ENGINE TORQUE





**ONE PASSION:
VICTORY**

SADEV has an exceptional record in supplying unique engineering to the most prestigious drivers and manufacturers. SADEV's products stand out for their technology, their excellence and their ambition. As precise as they are reliable, these high-tech masterpieces are the key to your victory. SADEV has just one goal: to make sure you win.

FOLLOW US



WWW.SADEV-TM.COM

6, rue Grand'Montains - 85110 SAINT-PROUANT - FRANCE

Tel: +33 (0)2 51 66 42 68

sadev@sadev-tm.com



A TEAM AT YOUR SIDE

| | |
|-----------------------|---|
| FRANCE | SADEV FRANCE - sadev@sadev-tm.com |
| USA | SADEV TRANSMISSIONS, INC. - info.usa@sadev-tm.com |
| UK | SWR MOTORSPORT LTD - servicesswrmotorsport@gmail.com |
| ITALY | GIEFFE RACING - info@giefferacing.com |
| SPAIN | DE LA PUENTE MOTORSPORT - dlpmotorsport@movistar.es |
| NETHERLANDS | RACING DEVELOPMENT - info@racingdevelopment.nl |
| NETHERLANDS | PETERS AUTOSPORT - bart@petersautosport.nl |
| BELGIUM | R TEC - info@rtec.ws |
| CZECH REPUBLIC | SADAC - info@sadac.cz |
| GERMANY | MTO ENGINEERING - info@mtoengineering.com |
| SWEDEN | HANSEN MOTORSPORT - kenneth@hansen-motorsport.se |
| DENMARK | GUNNAR AASKOV MOTORSPORT - mail@aaaskov-motorsport.dk |
| FINLAND | SET PROMOTION - kalle.pinomaki@setpromotion.com |
| SWITZERLAND | CHRISTIAN FERRARI - ferrach@bluewin.ch |
| SOUTH AFRICA | CENTURY RACING - julien@centuryracing.co.za |
| ARGENTINA | JPO RACING - racingjpo@gmail.com |
| BRAZIL | CD MOTORSPORT ENGINEERING - sadev.brasil@gmail.com |

