

RANGE  
**2WD**  
2 WHEEL DRIVE

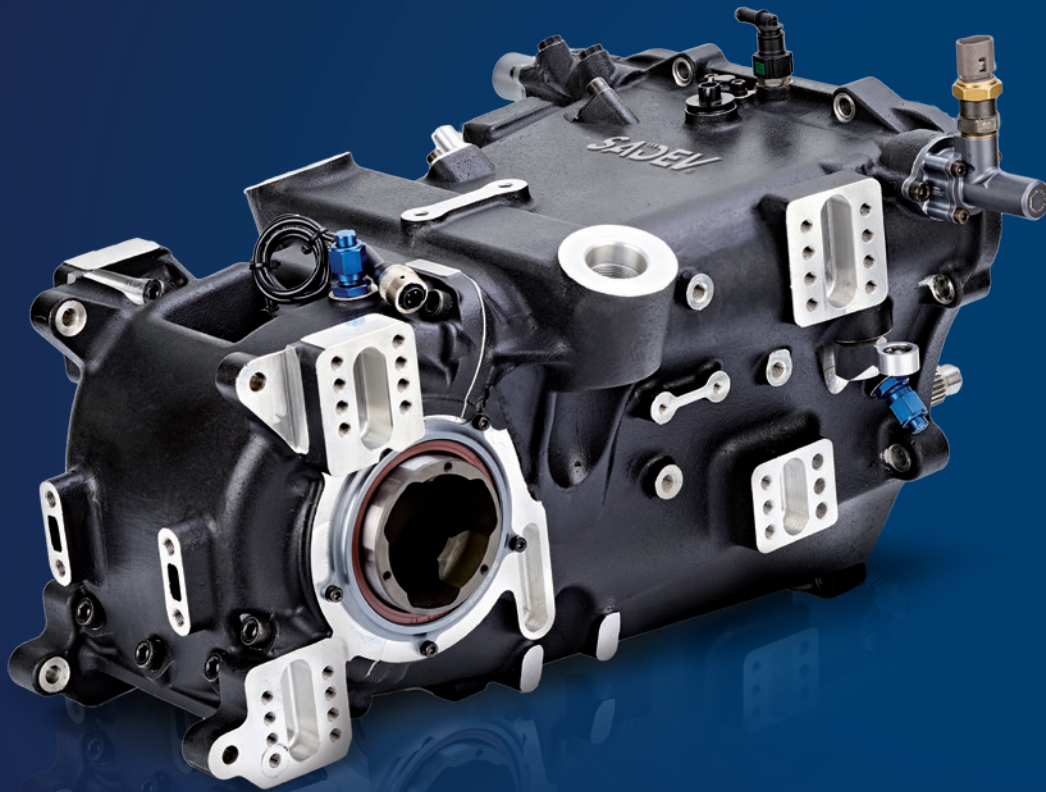

 **SLR82-14**  
TRANSAXLE

**SADEV**  
RACING TRANSMISSION

**SADEV**  
RACING TRANSMISSION

RANGE  
**2WD**  
2 WHEEL DRIVE



## **SLR82-14** TRANSAXLE

With its bold, streamlined design, the **SLR82-14** is part of the latest generation of SADEV gearboxes, combining experience with new technology. Our design and production tools enable an optimised footprint, increased robustness and reduced weight. And because cars are constantly evolving, the **SLR82-14** has to be ahead of the curve, offering integrated semi-automatic control and gears that can handle turbocharged engines.

### APPLICATIONS

- › *Circuit*
- › *Hill Climb*
- › *Single-seater*



## TECHNICAL SPECS

6 speed sequential gearbox + 1 reverse gear

Manual sequential gear selection (semi-auto optional)

Bevel gear ratio : 9x30 or 9x31

The bevel gear is cut and grinded in house on our CNC units

Wide range of ratios available

Straight cut gears

Dog ring gear engagement

Interchangeable gear ratios

High strength carburizing steel

Gear teeth grinded with optimized profile

Shot penning on internal parts

Specific input shaft

Hydraulic clutch bearing (optional)

Limited slip differential (free differential optional)

Ramp and plate system - 3 discs type

Preload made by spring washer

Wide range of ramp plates available

Contactless gear position sensor

Splash lubrication system

Oil pump integrated

Oil suction screen

Painted AS7G aluminum casings

Weight (input shaft included) : 48 kg - 105 lbs

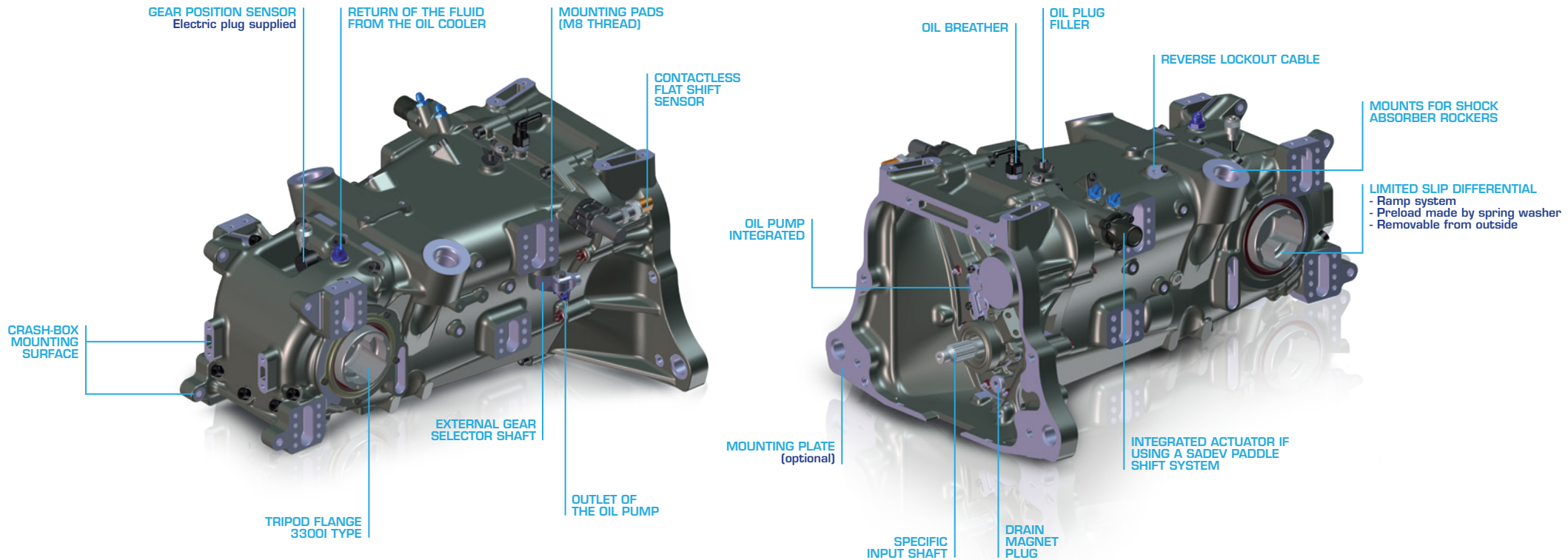

## ACCESSORIES

- › Gear display
- › Mounting plate
- › Push-pull cable
- › Drive shafts

### LIMITED SLIP DIFFERENTIAL

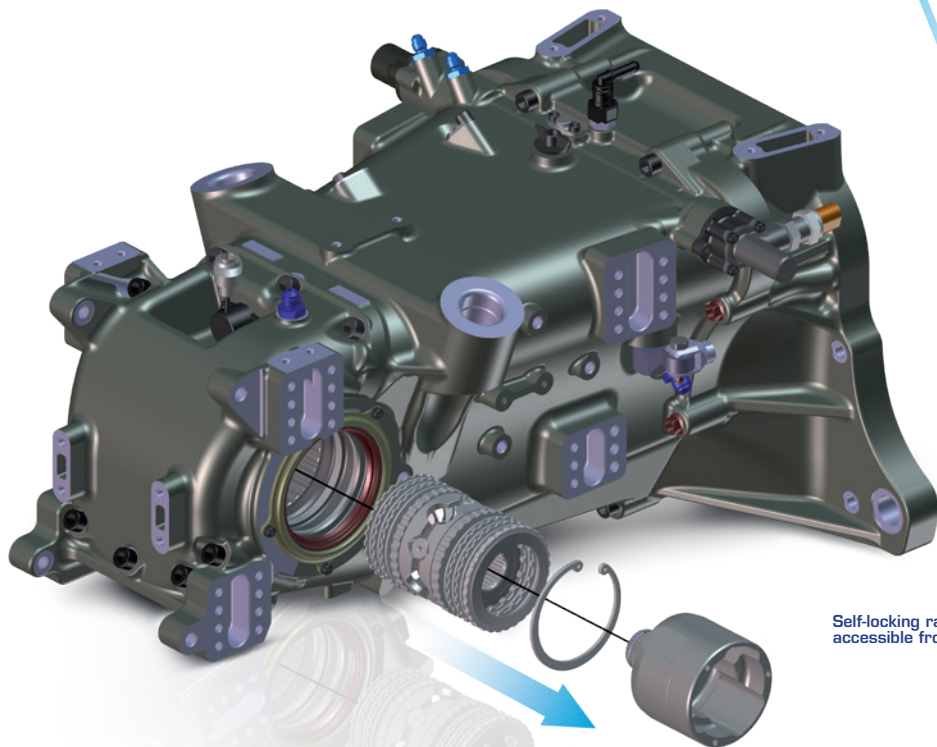

Self-locking ramp differential accessible from the outside

### HYDRAULIC PADDLE-SHIFT

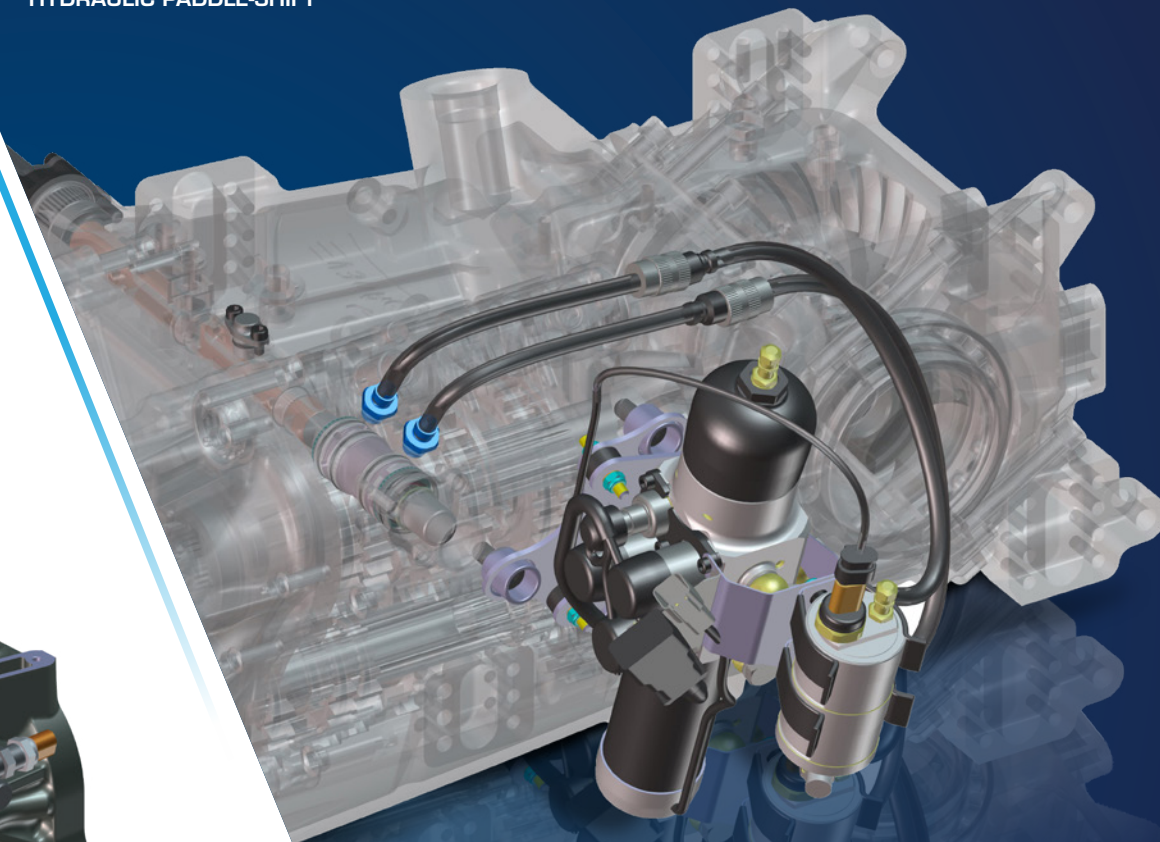

Possibility to connect the SADEV paddle-shift system and to operate the transmission via an integrated actuator.



## SLR82-14 TRANSAXLE

- › **Gears:** The **SLR82-14** benefits from optimised and strengthened gear tooth profiles for maximum efficiency.
- › **Selection:** An internal actuator can be fitted to the **SLR82-14** to receive the SADEV paddle-shift system.
- › **Architecture:** With its rear-mounted limited slip differential, the **SLR82-14** offers new opportunities for architecture design.
- › **Oil capacity:** The optimised casing design reduces the quantity of oil needed.
- › **Cooling:** An oil pump can be integrated with the **SLR82-14**. Driven mechanically, this enables an external oil cooler to be connected.

### MAXIMUM ENGINE TORQUE





## ONE PASSION: VICTORY

SADEV has an exceptional record in supplying unique engineering to the most prestigious drivers and manufacturers. SADEV's products stand out for their technology, their excellence and their ambition. As precise as they are reliable, these high-tech masterpieces are the key to your victory. SADEV has just one goal: to make sure you win.

FOLLOW US



[WWW.SADEV-TM.COM](http://WWW.SADEV-TM.COM)

6, rue Grand'Montains - 85110 SAINT-PROUANT - FRANCE

Tel: +33 (0)2 51 66 42 68

[sadev@sadev-tm.com](mailto:sadev@sadev-tm.com)



## A TEAM AT YOUR SIDE

<b>FRANCE</b>	SADEV FRANCE - <a href="mailto:sadev@sadev-tm.com">sadev@sadev-tm.com</a>
<b>USA</b>	SADEV TRANSMISSIONS, INC. - <a href="mailto:info.usa@sadev-tm.com">info.usa@sadev-tm.com</a>
<b>UK</b>	SWR MOTORSPORT LTD - <a href="mailto:serviceswrmotorsport@gmail.com">serviceswrmotorsport@gmail.com</a>
<b>ITALY</b>	GIEFFE RACING - <a href="mailto:info@giefferacing.com">info@giefferacing.com</a>
<b>SPAIN</b>	DE LA PUENTE MOTORSPORT - <a href="mailto:dlpmotorsport@movistar.es">dlpmotorsport@movistar.es</a>
<b>NETHERLANDS</b>	RACING DEVELOPMENT - <a href="mailto:info@racingdevelopment.nl">info@racingdevelopment.nl</a>
<b>NETHERLANDS</b>	PETERS AUTOSPORT - <a href="mailto:bart@petersautosport.nl">bart@petersautosport.nl</a>
<b>BELGIUM</b>	R TEC - <a href="mailto:info@rtec.ws">info@rtec.ws</a>
<b>CZECH REPUBLIC</b>	SADAC - <a href="mailto:info@sadac.cz">info@sadac.cz</a>
<b>GERMANY</b>	MTO ENGINEERING - <a href="mailto:info@mtoengineering.com">info@mtoengineering.com</a>
<b>SWEDEN</b>	HANSEN MOTORSPORT - <a href="mailto:kenneth@hansen-motorsport.se">kenneth@hansen-motorsport.se</a>
<b>DENMARK</b>	GUNNAR AASKOV MOTORSPORT - <a href="mailto:mail@aaaskov-motorsport.dk">mail@aaaskov-motorsport.dk</a>
<b>FINLAND</b>	SET PROMOTION - <a href="mailto:kalle.pinomaki@setpromotion.com">kalle.pinomaki@setpromotion.com</a>
<b>SWITZERLAND</b>	CHRISTIAN FERRARI - <a href="mailto:ferrach@bluewin.ch">ferrach@bluewin.ch</a>
<b>SOUTH AFRICA</b>	CENTURY RACING - <a href="mailto:julien@centuryracing.co.za">julien@centuryracing.co.za</a>
<b>ARGENTINA</b>	JPO RACING - <a href="mailto:racingjpo@gmail.com">racingjpo@gmail.com</a>
<b>BRAZIL</b>	CD MOTORSPORT ENGINEERING - <a href="mailto:sadev.brasil@gmail.com">sadev.brasil@gmail.com</a>

